

Beautiful LIVING

Transforming conservatories into an all year round living space



Transforming

LIVING SPACES

contents

PAGE 04	WELCOME
PAGE 06	LIGHTWEIGHT TILED ROOF
PAGE 10	LIGHTWEIGHT SLATE ROOF
PAGE 12	SKYVISTA GLASS PANEL FEATURE
PAGE 16	ROOF BREAKDOWN
PAGE 18	ROOF COVERINGS
PAGE 20	ACCESSORIES
PAGE 22	SUPALITE PITCHED ORANGERY
PAGE 24	CLIENT PEACE OF MIND
PAGE 26	FAQs

Welcome

Whether you are considering a conservatory roof replacement, new build conservatory or an extension, we have the solution for you.

The SupaLite Roof Systems have all undergone exhaustive testing following years of research and design. It's imperative that homeowners make the right decision when investing in a solid roof to ensure the building is a safe and habitable place that also adds value to the property.

Specifying the SupaLite Roof will ensure the correct configuration and overall solution for your all year round living space.

Quality living.
IT STARTS HERE

Transforming conservatories into
all year round living spaces



5 Reasons

to choose a **SupaLite Roof**

- ✓ Save money on heating costs
- ✓ Roof system engineered and tested to meet all Building Regulation requirements
- ✓ Transforms a conservatory into an extension
- ✓ Adds significant value to your home
- ✓ Increases your living & entertaining space

Lightweight **TILED ROOF**

Stylish. Practical. Innovative

STRUCTURAL lightweight aluminium roof, engineered and designed to last a lifetime.

INCREDIBLE U-Value with increased thermal performance which saves money on your energy bills.

WIDE CHOICE of tile and slate colours to either match or contrast your existing property.

ADD VALUE to your home with the feel of an extension for all year round living space.

Fall in love with your conservatory again

The transformation you will benefit from is incredible. Not only will you greatly reduce the energy costs by retaining a moderated living temperature in your conservatory, but you will also have more reason to spend time in your conservatory.

Before



After



We only used our old conservatory for half of the year as it was either too hot in summer or too cold in winter. By having the roof replaced with a SupaLite Roof, we now use this fabulous room all year round, morning till late at night. What a transformation!

Mr & Mrs Bramhall

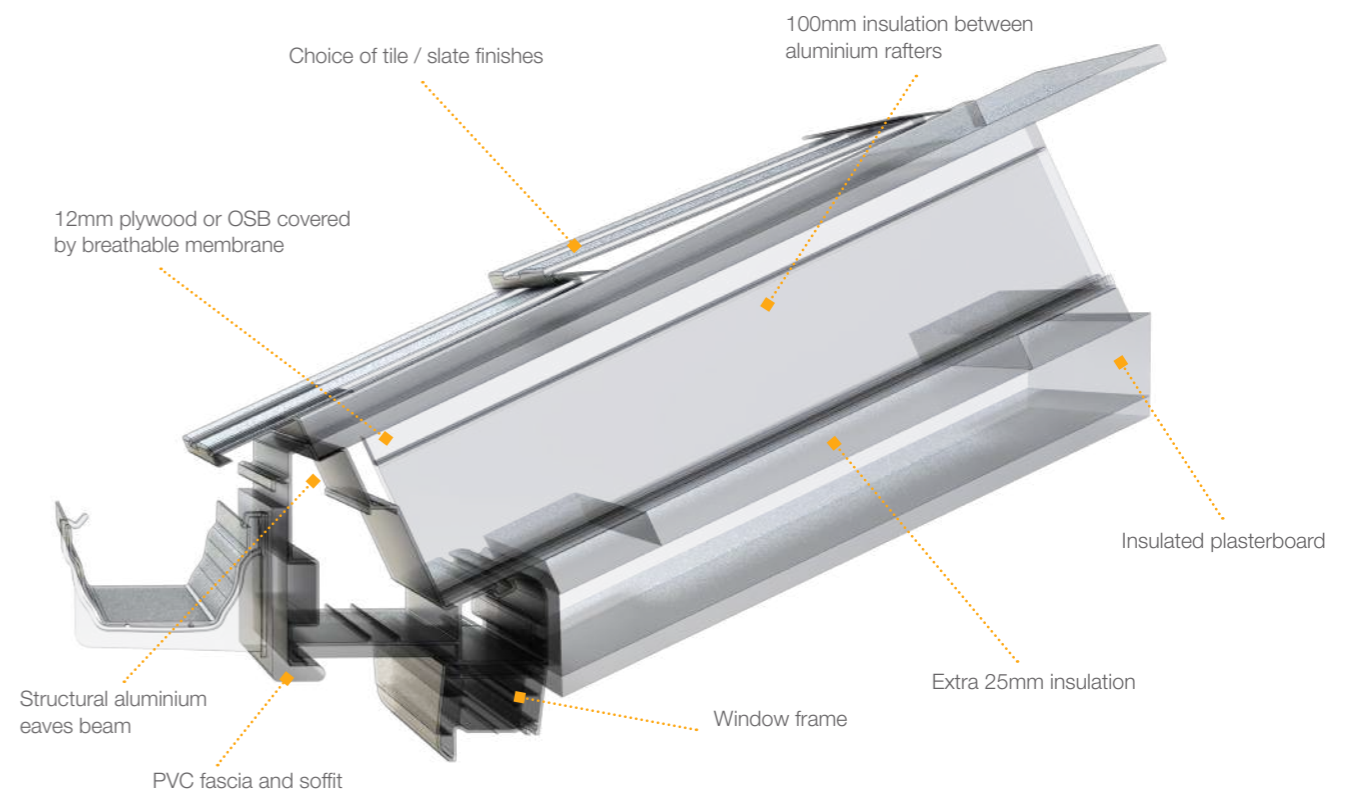

Lightweight **TILED ROOF**

Building your vision.
CREATING REALITY



UNIQUE fascia and soffit detail with options for external lighting to give the wow factor in the evenings.

COLOUR choice of fascias, soffits and guttering to either match or contrast your existing property.

10 YEAR GUARANTEE The SupaLite Roof is a tried and tested product, all our products are guaranteed for 10 years (excludes installation).

APPROVED Building Regulations compliant.

New Build, Replacement Roof or Commercial Building

The SupaLite Roof can be installed on new build conservatories or on new extensions.

Many commercial type properties are now installing the SupaLite Roof on restaurants, nursing homes, educational buildings and extensions.

These buildings will also benefit from the added property values gained by installing a SupaLite Roof.



Dream
Living Space

When SupaLite roofs are installed, many customers remodel their conservatories internally to give the feel of a true lounge or dining room. With plastered ceilings and our optional internal downlighting, it gives you a dream living space.

Lightweight **SLATE ROOF**

A complete investment.

ADDING VALUE TO YOUR PROPERTY

LIGHTWEIGHT

Even with SupaLite's 185mm of insulation, plasterboard, tiles, timber board, structural aluminium ridge, rafters and eaves beam – it will not be much heavier than a typical glass roof.

Ultra-modern with a Traditional Look

The SupaLite Slate roof comes with several colour options. The SupaLite Slate option can add splendour, elegance and tradition to your home. It is authentically shaped with textured surfaces and edges moulded from traditional slates, that make it almost indistinguishable from natural slate – yet it has an even more refined appearance. This lightweight slate will not crack, break or delaminate, and its product formulation and manufacturing processes provide durability, performance, and longevity for many years to come.

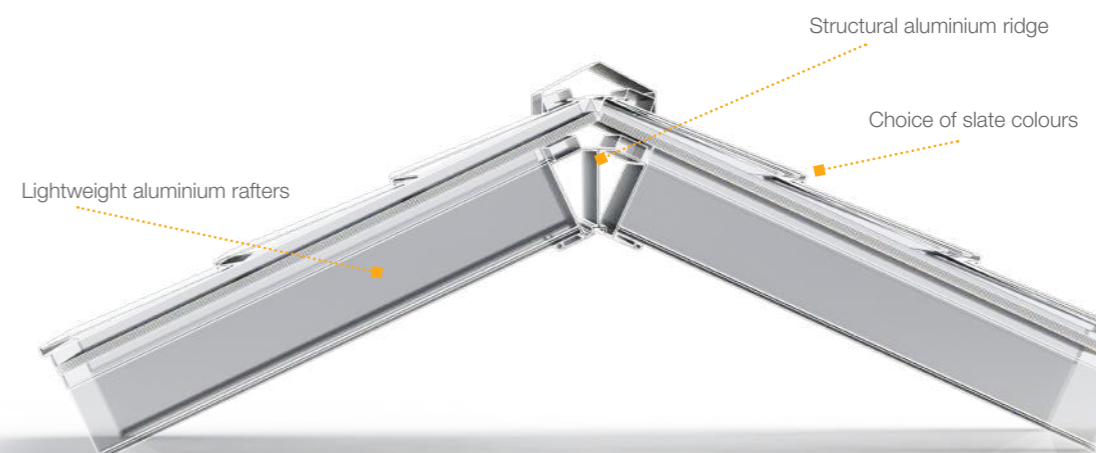

A typical edwardian style roof can span up to 6.5m (Int frame) utilising tie bars / ridge support beams

SKYVISTA

Glass Panel Feature



The place for you
TO RELAX AND ENJOY

The ultra-chic SkyVista panel has excellent aesthetic and great solar control, meaning you can regulate the temperature of your conservatory whilst allowing plenty of natural light to flow through.

A Beautiful and Practical Blend of Lightweight Tiles and Glass Panels

Control the temperature of your conservatory whilst making the most of natural light with our new product, the SupaLite SkyVista – a combination of our roof and glass panels.

Unlike traditional conservatory roofs, the technology behind the SkyVista means your conservatory will be cool and comfortable on hot sunny days and warm and cosy on cold winter days. Plus, you won't have to climb up ladders to clean your roof, as the SkyVista glass is self-cleaning.

The SkyVista can be configured to numerous conservatory styles, including Edwardian, Victorian and Lean-to.

5 Reasons to choose a SkyVista

- ✓ Transforms your conservatory into a solid roof system, without losing overhead natural light.
- ✓ The panels are available to be installed with both tile and slate finishing options.
- ✓ Awarding you with the best of both – part glass alongside our aluminium solid roof system.
- ✓ Stable thermal control within your newly transformed living space.
- ✓ Give your home a makeover with our stylish glass panel feature.

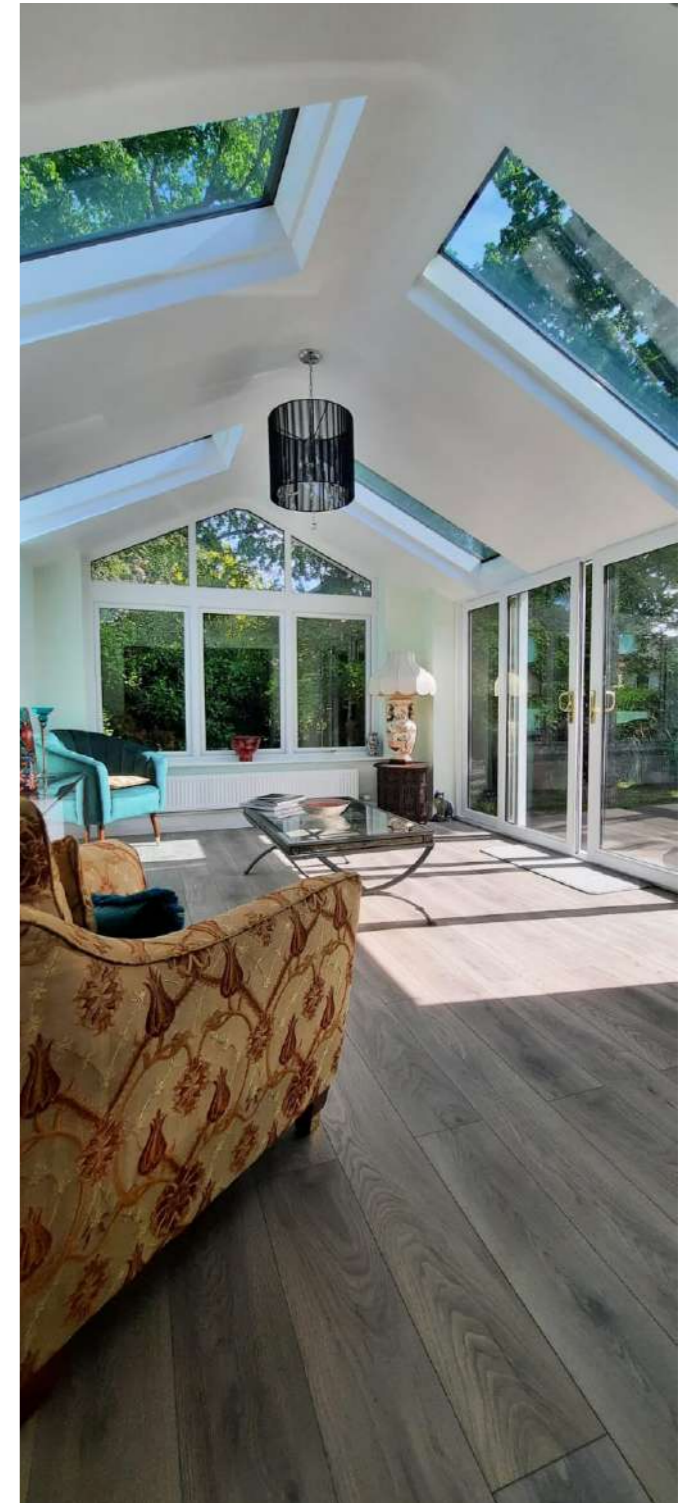

SKYVISTA

Glass Panel Feature

Excellence and innovation
BUILT INTO EVERY DESIGN

Glass Panels

The SkyVista glass panels feature blue solar control, self-cleaning glass, up to 3 metre lengths.

With a 60% solar heat reflection, that still allows 45% of natural light into the building, it's the best of glazing solutions.

SELF
CLEANING
GLASS

OUTSTANDING
SOLAR
CONTROL

SUPERB
THERMAL
PERFORMANCE

The Stylish Way of Adding More Light Into Your Home

The SkyVista glass panel feature allows a stylish look internally when plastered and painted. This allows more light into your home without over-heating in the summer.



SkyVista
By SupaLite

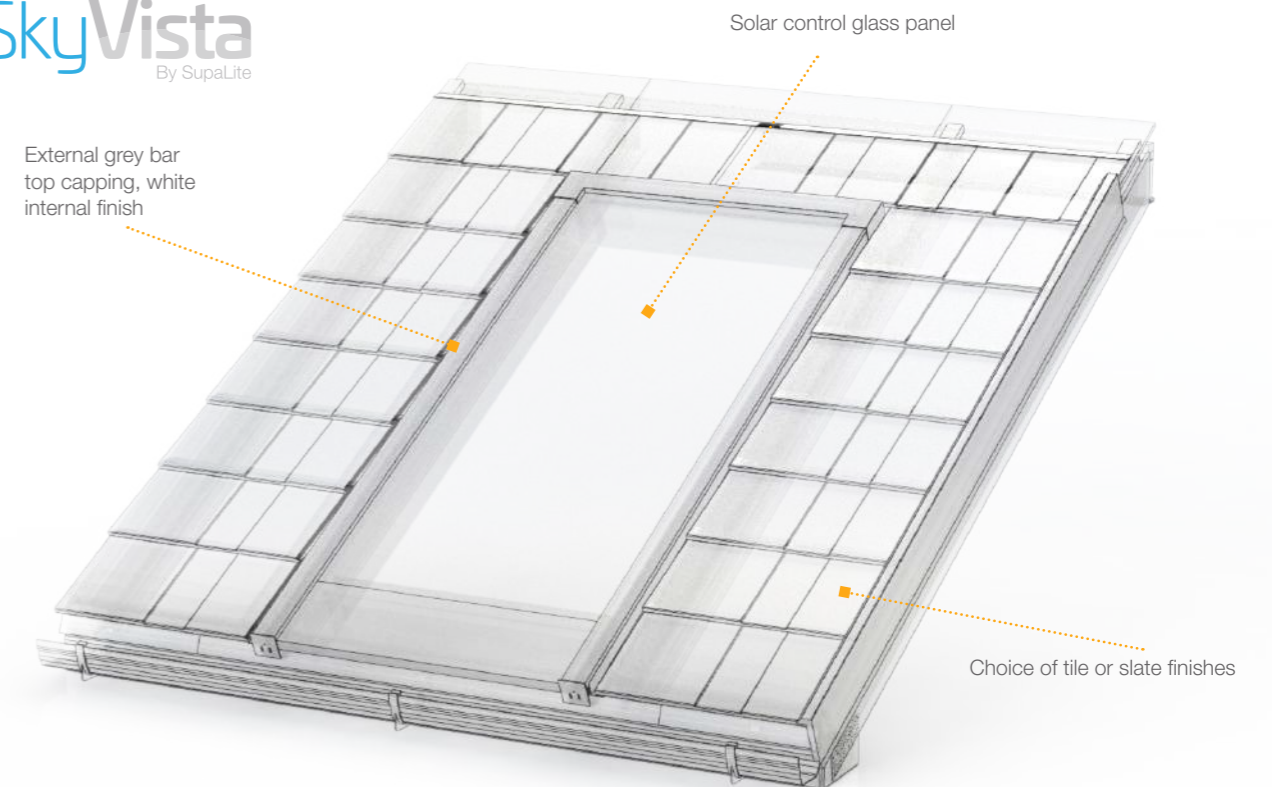

Designed & engineered
TO LAST A LIFETIME

U-VALUE
0.15
to meet building
regulation
specifications

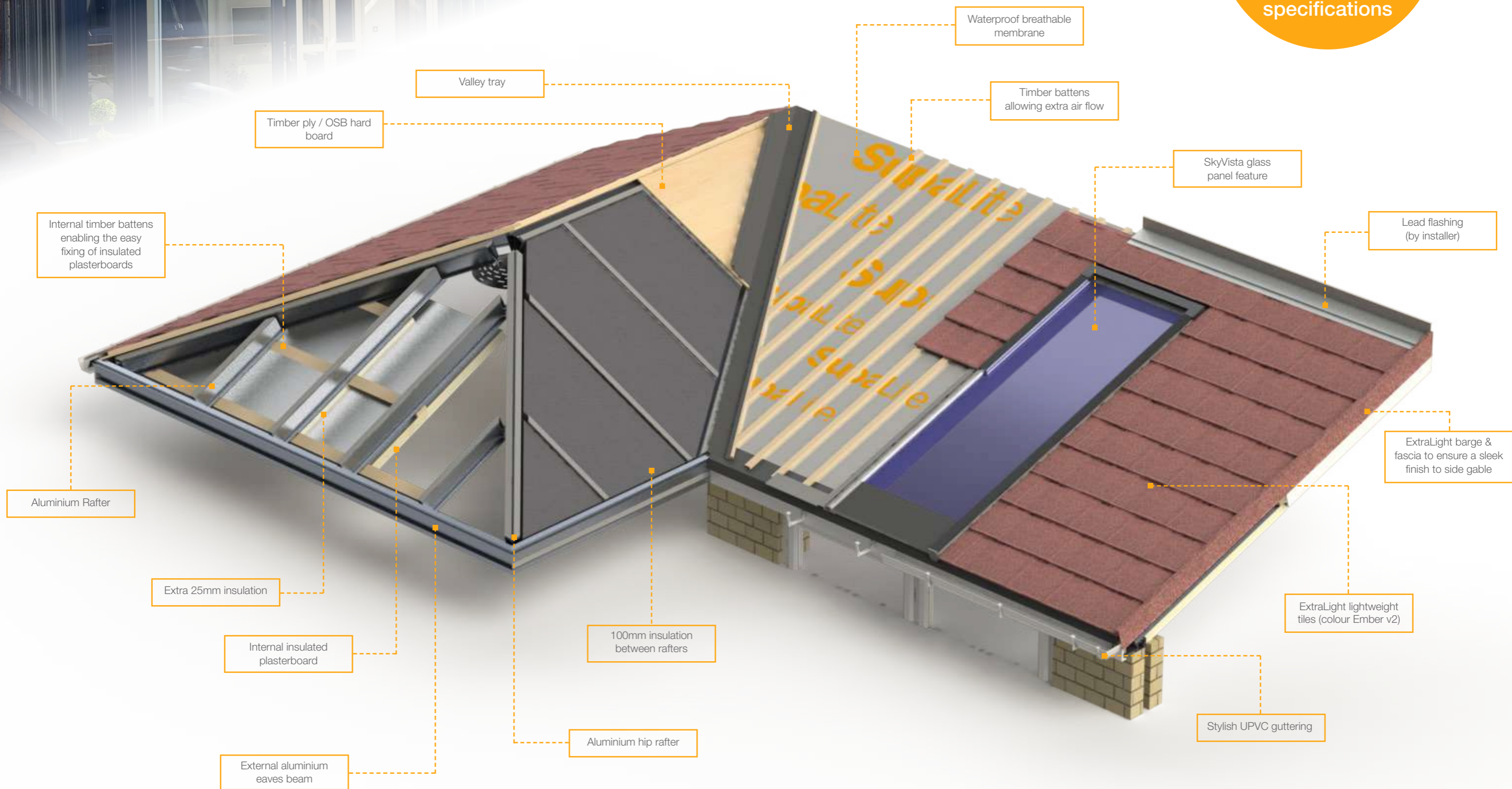

ROOF COVERINGS



Charcoal V2

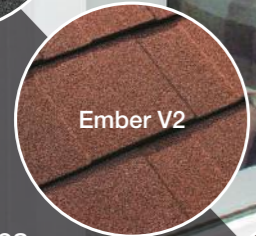

Ember V2



Walnut V2

ExtraLight high performance textured steel tiles are available in 3 colours. With its exceptional durability, the ExtraLight stone-coated steel tile offers superior performance.

extraLIGHT
LIGHTWEIGHT ROOF TILE SYSTEM

- ✓ **UNIQUE** - A new and unique high performance textured roof tile. The shingle textured-finish tile captures the subtle look and charm of low-profile traditional shingles.
- ✓ **PERFORMANCE** - ExtraLight eliminates the delaminating, lifting and general break-down caused by UV rays and high winds. Enjoy the superior performance of stone-coated steel.
- ✓ **CHOICE** - The ExtraLight Shingle comes in a choice of natural weathered tones to recreate the visual appeal of a clay tiled roof, carefully selected to match most traditional roofs.
- ✓ **APPROVED** - Our tiles are fully registered and compliant with the strict UK & European standards required for use with a roof pitch as low as 10 degrees.

The Traditional Slate Look

Roofing slate has for centuries been desired for its durability and aesthetic appeal, but it does have drawbacks with its weight, pitch restrictions and brittleness. The SupaLite Composite Slate Roof offers the look of traditional slate while remaining lightweight and hardwearing, boasting a 10-year guarantee. Manufactured by using recyclable materials virgin limestone and polypropylene, its performance has been approved and tested down to a minimum pitch of 14 degrees.

With a wide choice of 5 colours, this lightweight slate is a common roof covering choice for the SupaLite Roof System.



- Black
- Grey
- Brown
- Red
- Plum

ACCESSORIES



EXTERNAL LIGHTING - The unique design of the SupaLite Roof incorporates an external fascia and deep soffit. Many customers choose external LEDs to be fitted into the soffit creating a feature that is both functional and aesthetically pleasing in the evenings. With long life and low running costs the external LEDs can be left on all night in areas where security is needed.

Engineering
SIMPLICITY & PERFORMANCE

Transforming conservatories into
all year round living spaces



RIDGE SUPPORT BEAM - All roofs have to cater for 'Dead Load' (i.e. the weight of the roof).

When the deflections exceed an acceptable level, it is necessary to brace the structure with an additional support, namely a tie bar or ridge support beam.



COLOURED FASCIAS & SOFFITS - The soffit board is tucked away under the fascia board. It is usually the fascia and soffit that you see most of from street level. The SupaLite roof system incorporates these to match the existing property aesthetics, including most colour options. It also accommodates external soffit lights.



INTERNAL LIGHTING - LED ceiling lights are a sleek and stylish way to add energy efficient and up to date lighting to your home. LED bulbs have an impressive life span and use up to 90% less energy. These can be fitted in the ridge bulkhead or a pelmet closer to the eaves beam.



ROOF WINDOW - Roof lights and roof ventilation have been in popular use for the past 150 years.

Our high-quality materials, state of the art production techniques and excellent quality control ensure we provide durable, safe and functional roof windows. The internal colour options of our roof windows are white or pine.

SUPALITE PITCHED ORANGERY

Unique
IN DESIGN



Transform Your Orangery

A thermally efficient Pitched Orangery roof combines style, performance and versatility.

The SupaLite Pitched Orangery system is the most modern and efficient way to enjoy both the indoors and outdoors whilst remaining light and warm. Unique to SupaLite, our Pitched Orangery roof offers excellent thermal efficiency as well as being stunning to behold, both internally and externally.

Choose from a range of lightweight tile finishes combined with a robust yet elegant glass lantern to create a bespoke, contemporary look for your property that's designed to last a lifetime.



"We have completely remodelled our old conservatory by adding brick columns, bi-folding doors and a SupaLite Orangery to create a modern dining room with an open-air feel. It's great for entertaining and the combination of warmth and natural light suits us perfectly!"

Mr & Mrs Stanworth

5 Reasons to choose a SupaLite Pitched Orangery

- ✓ Wide choice of tile finishes
- ✓ Adds more natural light
- ✓ Choice of colours for glazed lantern
- ✓ Sleek internal plaster lines due to roof slopes
- ✓ A contemporary design that's unique to SupaLite

Did you know?

A SupaLite Tiled Roof System is fully calculated and accredited for building regulations approval, giving you peace of mind that your new conservatory roof is compliant and safe.

The SupaLite Tiled Roof System has been specifically tailored to meet building control standards.

Roof conversions are required by law to comply with building regulations, so it's imperative that companies fully understand the process and can ensure all installations comply with the legal requirements. We utilise a network of Registered Installers who are trained to do this.

Questions to ask?

- Building regulation certificate issued (if applied for)
- Compliant to JHA1 specification
- SupaLite 10 year product guarantee
- Structurally proven even under heavy snowfall
- Roof structure designed to take plasterboard, tiles & vents
- Thermally efficient cool in summer, warm in winter
- Free from mould and condensation
- Free from solicitor issues if the house is sold
- A worry free all year round living space for the homeowner

SupaLite TILED ROOF SYSTEM	Non-Compliant Roofs
✓	✗
✓	✗
✓	✗
✓	✗
✓	✗
✓	✗
✓	✗
✓	✗
✓	✗



Did you know?

If the council are made aware of a clad-over roof being installed at a property, they could enforce you to remove it.



BEWARE of Clad-overs!

WHAT IS A CLAD-OVER?

Some companies simply clad-over the existing conservatory roof internally, externally or both. Either way, they plan to use the existing structure that was only ever designed for its original purpose. These will be more competitively priced but may not meet Building Regulation Approval. Don't be frightened of asking the builder/installer about the following:

U-VALUE

Does the new structure achieve the correct U-Value for insulation properties?

CONDENSATION

Are there thermal barriers and enough air ventilation in place? Ask to see a small product sample if needed for proof of this.

STRUCTURAL INTEGRITY / CALCULATIONS

Can the new roof structure withstand wind and snow loadings? If in doubt request structural calculations for the roof. If this is a tried and tested system, these will be available.

WEIGHT

Clad-over companies simply remove your polycarbonate or glass and clad-over a structure designed to carry a lot less weight. Tiled roofs need to be stronger to prevent plaster cracking.

WARRANTY

What guarantee will you get and will your home insurance pay-out if there's a problem?

Make the right decision by choosing a SupaLite roof and not a 'clad-over' when replacing your existing conservatory roof.

Having peace of mind and knowing that you can get payback on your investment is vital and installing a SupaLite roof will give you just that. Combining this with Building Regulations approval means that, if you come to sell your property, the structure will be a fully compliant living space.

"We got three separate quotations when considering replacing our conservatory roof. One of them was several £1000s cheaper which we considered initially. It was only when I asked for some evidence of the proposed roof performance, structure and insulation values, we quickly changed our mind! I'm so glad we did as our new SupaLite roof came with Building Regulations and we know that we'll get back the money we spent on the work, if we come to sell our house."

Mr & Mrs Hewit

What is the weight, per square meter, for a SupaLite tiled roof?

- The weight of the tiled roof is 46kg per m², however, this may vary by roof style.

Do I get a guarantee with the SupaLite roof?

- We provide a 10-year product guarantee on our SupaLite Roofs to the installation company. The installation company should issue their own guarantee as the SupaLite product guarantee does not cover any installation work.

Typically, how long does it take to install the SupaLite conservatory roof?

- Typically, it would take 2 - 3 days to install a SupaLite conservatory roof for a standard sized 4m x 4m Edwardian style conservatory, excluding plastering & internal finish.

Do I need to get planning permission to install a SupaLite conservatory roof?

- Planning permission is generally not required to install a SupaLite conservatory roof, if you are only replacing the roof on your existing conservatory. However, if your existing conservatory needed permission you may need permission to change the roof.

Will having a SupaLite conservatory roof increase the value of my home?

- A SupaLite conservatory roof could significantly increase the value of your home, especially with a Building Regulation Certificate.

Will it make the room darker if I have a SupaLite conservatory roof installed?

- There is a possibility that your room may be darker once you replace your existing roof with a SupaLite conservatory roof, but there are ways of making your new room lighter. This includes painting the ceiling white, installing internal spot lights, Roof Windows or SkyVista glass panels.

Installers Nationwide

Find out more about replacing your existing conservatory roof with a SupaLite Tiled Roof System by visiting our website www.supaliteroof.co.uk.

Insist on the best,
insist on **SupaLite**

**CORGI Certification**

SupaLite are the first tiled roof company to be assessed and issued with membership of the respected CORGI Fenestration scheme for supply chain quality and continuity.

ENGINEERING SIMPLICITY & PERFORMANCE



Join the revolution
INSIST ON A SUPALITE ROOF



www.supaliteroof.co.uk

SupaLite Tiled Roof Systems Ltd

180-181 Bradkirk Place | Walton Summit | Preston | PR5 8AJ

01772 82 80 60 | sales@supaliteroof.co.uk | www.supaliteroof.co.uk